

LARGE ALUMINUM ELECTROLYTIC CAPACITORS

HC Snap-in Terminal Type, Standard Series

- Standard snap-in terminal type
- Including height 20mm products, low profile sized (Voltage range of 160 ~ 450V)
- Complied to the RoHS directive



Item	Characteristics																	
Operating temperature range	WV ≤ 350 : -40 ~ +85°C, WV > 350 : -25 ~ +85°C																	
Capacitance tolerance	±20% at 120Hz, 20°C																	
Leakage current max.	$I = 3\sqrt{CV}$ (µA) (after 5 minutes)																	
Dissipation factor max. (at 120Hz, 20°C)	Capacitance > 1000µF : tanδ increases by 0.01 for each 1000µF from below value.																	
	<table border="1"> <thead> <tr> <th>WV</th> <th>6.3</th> <th>10</th> <th>16, 25</th> <th>35</th> <th>50, 63</th> <th>80, 100</th> <th>160 ~ 400</th> <th>450, 500</th> </tr> </thead> <tbody> <tr> <td>tanδ</td> <td>0.45</td> <td>0.40</td> <td>0.35</td> <td>0.30</td> <td>0.25</td> <td>0.20</td> <td>0.15</td> <td>0.20</td> </tr> </tbody> </table>	WV	6.3	10	16, 25	35	50, 63	80, 100	160 ~ 400	450, 500	tanδ	0.45	0.40	0.35	0.30	0.25	0.20	0.15
WV	6.3	10	16, 25	35	50, 63	80, 100	160 ~ 400	450, 500										
tanδ	0.45	0.40	0.35	0.30	0.25	0.20	0.15	0.20										
Load life (after application of the rated voltage for 2000 hours at 85°C)	Leakage current	Less than specified value																
	Capacitance change	Within ±20% of initial value																
	tanδ	Less than 200% of specified value																
Shelf life (after leaving capacitors under no load at 85°C for 1000 hours)	Leakage current	Less than specified value																
	Capacitance change	Within ±15% of initial value																
	tanδ	Less than 150% of specified value																

● DRAWING

Unit : mm

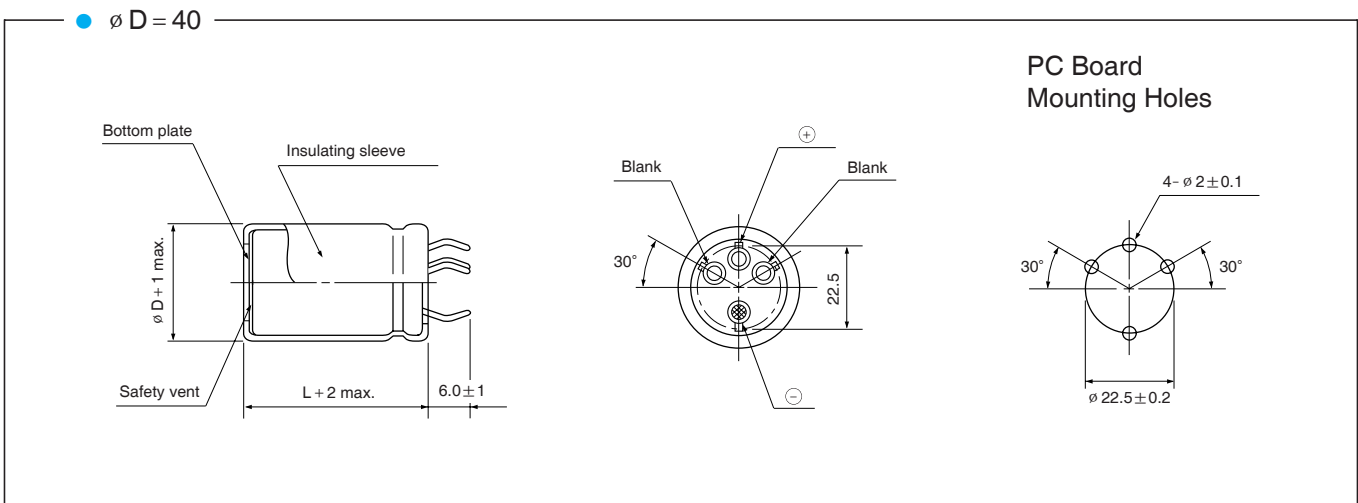
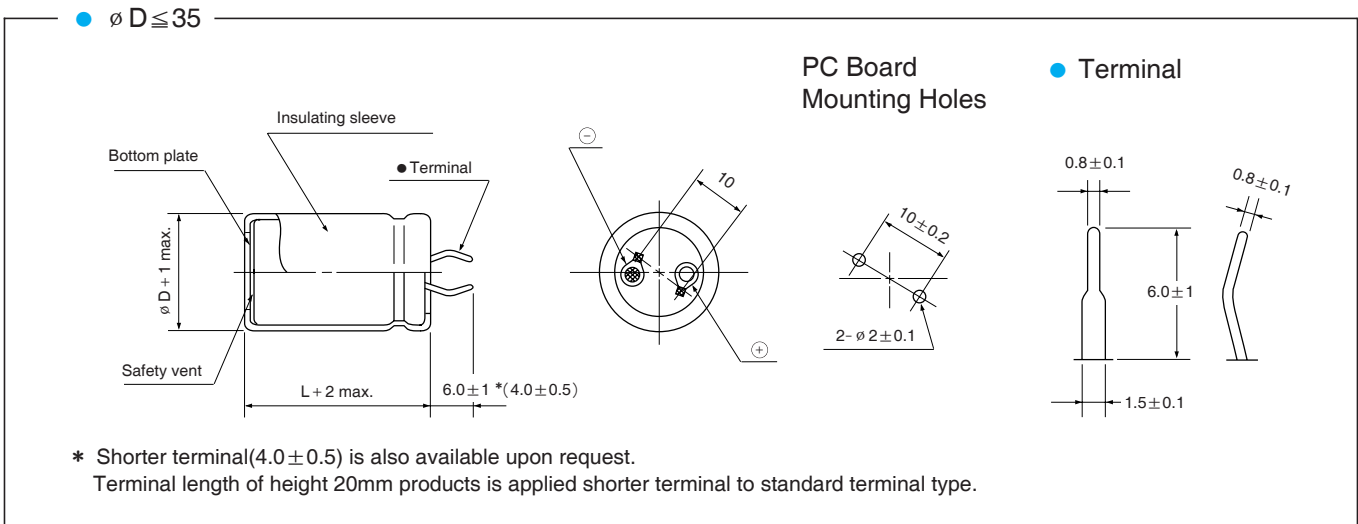

HC series

● DIMENSIONS & MAXIMUM PERMISSIBLE RIPPLE CURRENT

WV μF ∅ D	6.3					10					16				
	22	25.4	30	35	40	22	25.4	30	35	40	22	25.4	30	35	40
10000											22 × 25 3.32				
12000						22 × 25 3.31					22 × 30 3.55	25.4 × 25 3.89			
15000	22 × 25 3.39					22 × 30 3.82	25.4 × 25 3.39				22 × 35 4.29	25.4 × 30 4.45	30 × 25 4.56		
18000	22 × 30 3.85	25.4 × 25 3.96				22 × 35 4.28	25.4 × 25 4.17				22 × 40 4.77	25.4 × 35 4.96	30 × 30 5.10		
22000	22 × 35 4.34	25.4 × 25 4.22				22 × 40 4.79	25.4 × 30 4.71	30 × 25 4.83			22 × 50 5.51	25.4 × 40 5.51	30 × 30 5.39		
27000	22 × 40 4.85	25.4 × 30 4.77	30 × 25 4.89			22 × 45 5.30	25.4 × 35 5.26	30 × 30 5.41				25.4 × 45 6.06	30 × 35 5.98	35 × 25 5.80	
33000	22 × 45 5.36	25.4 × 35 5.32	30 × 30 5.47			22 × 50 5.82	25.4 × 40 5.81	30 × 30 5.69	35 × 25 5.81				30 × 40 6.56	35 × 30 6.41	
39000	22 × 50 5.83	25.4 × 40 5.82	30 × 30 5.70	35 × 25 5.82			25.4 × 45 6.31	30 × 35 6.22	35 × 30 6.38				30 × 45 7.08	35 × 35 6.96	
47000		25.4 × 45 6.35	30 × 35 6.26	35 × 30 6.41			25.4 × 50 6.83	30 × 40 6.78	35 × 30 6.62				30 × 50 7.62	35 × 40 7.54	
56000		25.4 × 50 6.85	30 × 40 6.80	35 × 30 6.64				30 × 45 7.31	35 × 35 7.18					35 × 45 8.08	40 × 40 8.23
68000			30 × 45 7.35	35 × 35 7.23					35 × 40 7.76					35 × 50 8.63	40 × 50 9.13
100000				35 × 45 8.34	40 × 40 8.49					40 × 50 9.35					40 × 60 10.2

WV μF ∅ D	25					35					50				
	22	25.4	30	35	40	22	25.4	30	35	40	22	25.4	30	35	40
3300											22 × 30 2.97	25.4 × 25 3.06			
4700						22 × 30 3.06	25.4 × 25 2.98				22 × 40 3.83	25.4 × 35 3.98	30 × 25 3.86	35 × 25 4.19	
5600	22 × 25 2.65					22 × 35 3.28	25.4 × 30 3.39				22 × 45 4.26	25.4 × 40 4.44	30 × 30 4.35	35 × 25 4.44	
6800	22 × 30 3.06	25.4 × 25 3.15				22 × 40 3.73	25.4 × 30 3.67	30 × 25 3.76			22 × 50 4.77	25.4 × 40 4.76	30 × 35 4.92	35 × 30 5.04	
8200	22 × 35 3.45	25.4 × 30 3.57				22 × 45 4.13	25.4 × 35 4.10	30 × 30 4.22				25.4 × 50 5.43	30 × 40 5.38	35 × 30 5.26	
10000	22 × 40 3.95	25.4 × 30 3.89	30 × 25 3.99			22 × 50 4.68	25.4 × 40 4.68	30 × 30 4.58					30 × 45 6.07	35 × 35 5.97	
12000	22 × 45 4.41	25.4 × 35 4.37	30 × 30 4.50				25.4 × 45 5.18	30 × 35 5.11	35 × 30 5.24				30 × 50 6.62	35 × 40 6.55	
15000	22 × 50 4.94	25.4 × 40 4.94	30 × 35 5.10					30 × 40 5.72	35 × 35 5.88					35 × 45 7.20	
18000		25.4 × 45 5.45	30 × 35 5.38	35 × 30 5.51				30 × 45 6.28	35 × 40 6.46					35 × 50 7.74	40 × 40 7.62
22000			30 × 45 6.22	35 × 35 6.12					35 × 45 7.07	40 × 40 7.20					40 × 50 8.54
27000			30 × 50 6.82	35 × 40 6.74						40 × 50 8.14					40 × 60 9.45
33000				35 × 45 7.35	40 × 40 7.48					40 × 50 8.46					

WV μF ∅ D	63					80					100				
	22	25.4	30	35	40	22	25.4	30	35	40	22	25.4	30	35	40
1200						22 × 25 2.24					22 × 30 2.39	25.4 × 25 2.46			
1500						22 × 30 2.67					22 × 35 2.83	25.4 × 30 2.93	30 × 25 3.00		
1800	22 × 25 2.20					22 × 30 2.92	25.4 × 25 3.01				22 × 40 3.26	25.4 × 35 3.39	30 × 30 3.49		
2200	22 × 30 2.50	25.4 × 25 2.58				22 × 35 3.25	25.4 × 30 3.36	30 × 25 3.45			22 × 45 3.58	25.4 × 40 3.74	30 × 30 3.66		
2700	22 × 35 2.94	25.4 × 30 3.04				22 × 40 3.79	25.4 × 35 3.94	30 × 30 4.05				25.4 × 45 4.33	30 × 35 4.27	35 × 30 4.37	
3300	22 × 35 3.14	25.4 × 30 3.26	30 × 25 3.34			22 × 45 4.18	25.4 × 40 4.36	30 × 30 4.27				25.4 × 50 4.76	30 × 40 4.72	35 × 35 4.85	
3900	22 × 40 3.60	25.4 × 35 3.74	30 × 30 3.85			22 × 50 4.75	25.4 × 45 4.96	30 × 35 4.89					30 × 45 5.36	35 × 35 5.27	
4700	22 × 50 4.19	25.4 × 40 4.19	30 × 35 4.10	35 × 30 4.19			25.4 × 50 5.44	30 × 40 5.39	35 × 30 5.27				30 × 50 5.86	35 × 40 5.80	
5600		25.4 × 45 4.65	30 × 35 4.58	35 × 30 4.70				30 × 45 5.91	35 × 35 5.81					35 × 45 6.34	40 × 40 6.45
6800		25.4 × 50 5.20	30 × 40 5.16	35 × 30 5.04					35 × 40 5.46						40 × 50 7.40
8200			30 × 45 5.62	35 × 35 5.53					35 × 45 6.91	40 × 40 7.04					40 × 50 7.60
10000			30 × 50 6.32	35 × 40 6.25						40 × 50 8.14	← Case size ∅ D × L (mm) ← Ripple current (Arms) at 85°C, 120Hz				
12000				35 × 45 6.83	40 × 40 6.95										

* Note: Case diameter (∅ 20) is available upon request.

LARGE TYPES

LARGE ALUMINUM ELECTROLYTIC CAPACITORS

HC series

● DIMENSIONS & MAXIMUM PERMISSIBLE RIPPLE CURRENT

WV μF ∅ D	160					200					250				
	22	25.4	30	35	40	22	25.4	30	35	40	22	25.4	30	35	40
150											22 × 25 0.90	25.4 × 20 0.92			
180						22 × 20 0.91					22 × 25 0.90	25.4 × 20 1.01			
220	22 × 20 1.01					22 × 25 1.09	25.4 × 20 1.11				22 × 25 1.09	25.4 × 25 1.19	30 × 20 1.22		
270	22 × 25 1.20	25.4 × 20 1.32				22 × 25 1.20	25.4 × 25 1.32	30 × 20 1.35			22 × 30 1.28	25.4 × 25 1.32	30 × 20 1.35		
330	22 × 25 1.33	25.4 × 20 1.36				22 × 30 1.42	25.4 × 25 1.46	30 × 20 1.49			22 × 35 1.50	25.4 × 30 1.56	30 × 25 1.60	35 × 20 1.62	
390	22 × 25 1.45	25.4 × 25 1.59	30 × 20 1.62			22 × 30 1.54	25.4 × 25 1.59	30 × 25 1.74	35 × 20 1.77		22 × 40 1.72	25.4 × 30 1.69	30 × 25 1.73	35 × 20 1.77	
470	22 × 30 1.69	25.4 × 25 1.75	30 × 20 1.78			22 × 35 1.79	25.4 × 30 1.86	30 × 25 1.90	35 × 20 1.94		22 × 45 1.98	25.4 × 35 1.96	30 × 30 2.02	35 × 25 2.06	
560	22 × 35 1.96	25.4 × 30 2.03	30 × 25 2.08	35 × 20 2.12		22 × 40 2.06	25.4 × 35 2.14	30 × 25 2.08	35 × 25 2.25		22 × 50 2.26	25.4 × 40 2.25	30 × 30 2.20	35 × 25 2.25	
680	22 × 40 2.27	25.4 × 30 2.23	30 × 25 2.29	35 × 20 2.33		22 × 45 2.38	25.4 × 40 2.48	30 × 30 2.43	35 × 25 2.48			25.4 × 45 2.60	30 × 35 2.56	35 × 30 2.62	
820	22 × 45 2.61	25.4 × 35 2.59	30 × 30 2.67	35 × 25 2.73		22 × 50 2.73	25.4 × 45 2.85	30 × 35 2.81	35 × 30 2.88				30 × 40 2.95	35 × 35 3.03	
1000	22 × 50 3.01	25.4 × 40 3.01	30 × 30 2.95	35 × 25 3.01				30 × 40 3.26	35 × 30 3.18				30 × 45 3.40	35 × 40 3.50	
1200		25.4 × 45 3.23	30 × 35 3.18	35 × 30 3.26				30 × 45 3.49	35 × 35 3.43					35 × 45 3.74	40 × 40 3.81
1500			30 × 40 3.73	35 × 35 3.83				30 × 50 4.06	35 × 40 4.01					35 × 50 4.35	40 × 50 4.60
1800				35 × 40 4.39	40 × 40 4.66				35 × 45 4.58	40 × 40 4.66					40 × 60 5.39

WV μF ∅ D	315					350					400				
	22	25.4	30	35	40	22	25.4	30	35	40	22	25.4	30	35	40
68											22 × 20 0.56				
82						22 × 20 0.62					22 × 25 0.66	25.4 × 20 0.68			
100	22 × 20 0.68					22 × 25 0.73	25.4 × 20 0.75				22 × 30 0.78	25.4 × 25 0.81	30 × 20 0.82		
120	22 × 25 0.80	25.4 × 20 0.82				22 × 30 0.86	25.4 × 25 0.88	30 × 20 0.90			22 × 30 0.86	25.4 × 25 0.88	30 × 20 0.90		
150	22 × 30 0.96	25.4 × 25 0.99	30 × 20 1.01			22 × 35 1.01	25.4 × 30 1.05	30 × 20 1.01			22 × 35 1.01	25.4 × 30 1.05	30 × 25 1.08	35 × 20 1.09	
180	22 × 35 1.11	25.4 × 30 1.15	30 × 25 1.18	35 × 20 1.20		22 × 40 1.17	25.4 × 35 1.21	30 × 25 1.18	35 × 20 1.20		22 × 40 1.17	25.4 × 35 1.21	30 × 25 1.18	35 × 25 1.28	
220	22 × 40 1.29	25.4 × 30 1.27	30 × 25 1.30	35 × 20 1.33		22 × 45 1.35	25.4 × 35 1.34	30 × 30 1.38	35 × 25 1.41		22 × 45 1.35	25.4 × 40 1.41	30 × 30 1.38	35 × 25 1.41	
270	22 × 45 1.50	25.4 × 35 1.49	30 × 30 1.53	35 × 25 1.56			25.4 × 45 1.64	30 × 35 1.61	35 × 25 1.65			25.4 × 45 1.64	30 × 35 1.61	35 × 30 1.65	
330	22 × 50 1.73	25.4 × 40 1.73	30 × 35 1.78	35 × 30 1.83			25.4 × 50 1.89	30 × 40 1.87	35 × 30 1.83			25.4 × 50 1.89	30 × 40 1.87	35 × 30 1.83	
390		25.4 × 45 1.97	30 × 35 1.94	35 × 30 1.99				30 × 45 2.12	35 × 35 2.09				30 × 45 2.12	35 × 35 2.09	
470			30 × 40 2.23	35 × 35 2.29				30 × 50 2.43	35 × 40 2.40				30 × 50 2.43	35 × 40 2.40	
560				35 × 40 2.62					35 × 45 2.73					35 × 45 2.73	40 × 40 2.78
680				35 × 45 3.01					35 × 50 3.13	40 × 40 3.06					40 × 50 3.31
820				35 × 50 3.44	40 × 40 3.37					40 × 50 3.63					40 × 60 3.89

WV μF ∅ D	450					500				
	22	25.4	30	35	40	22	25.4	30	35	40
56	22 × 20 0.51									
68	22 × 25 0.60	25.4 × 20 0.62				22 × 30 0.49				
82	22 × 30 0.71	25.4 × 25 0.73	30 × 20 0.74			22 × 35 0.57	25.4 × 30 0.59			
100	22 × 35 0.83	25.4 × 30 0.86	30 × 25 0.88	35 × 20 0.89		22 × 40 0.67	25.4 × 35 0.69			
120	22 × 40 0.95	25.4 × 35 0.99	30 × 25 0.96	35 × 20 0.98			25.4 × 40 0.80			
150	22 × 50 1.17	25.4 × 40 1.17	30 × 30 1.14	35 × 25 1.17				30 × 35 0.92		
180		25.4 × 45 1.34	30 × 35 1.32	35 × 25 1.28				30 × 40 1.06		
220		25.4 × 50 1.54	30 × 40 1.53	35 × 30 1.49				30 × 45 1.22		
270			30 × 45 1.77	35 × 35 1.74					35 × 45 1.45	
330			30 × 50 2.03	35 × 40 2.01					35 × 50 1.66	
390				35 × 45 2.28						
470				35 × 50 2.60	40 × 40 2.55					40 × 50 2.10
560					40 × 50 3.00					40 × 60 2.45
680					40 × 60 3.54					40 × 60 2.70

← Case size ∅ D × L (mm)
 ← Ripple current (Arms) at 85°C, 120Hz